



# CTP STONE-GRIP TIE

-- Submittal --



## CTP 6300-2 SERIES ANCHOR

Requires CTP Hex Key, CTP 501 Setting Tool, Compression Sleeve Positioning Tool and 1/2" Deep Well Socket

*Type 2 : Wind load restraint for uni-direction loading to wood or steel back-up.*

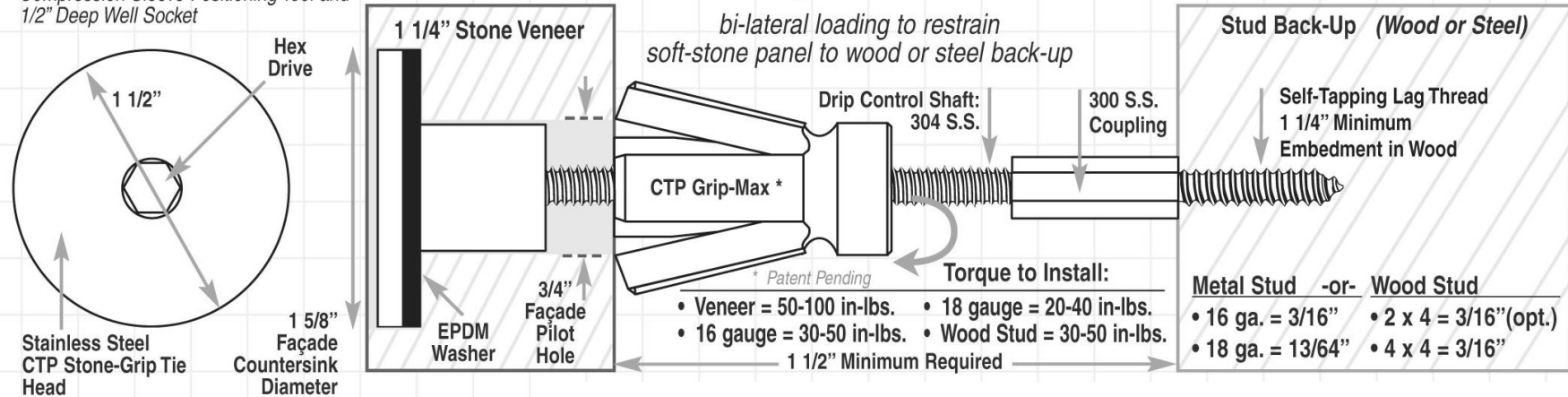

• Brass: ASTM B16, Type 360

• S.S : ASTM A-580, Type 304 ; ASTM A-276

### Length

- 5 1/2 " (138mm)       7 1/2 " (188mm)       9 1/2 " (238mm)
- 6 1/2 " (163mm)       8 1/2 " (213mm)       Other

### Head Style

- Round (as shown)    Other \_\_\_\_\_
- Color** \_\_\_\_\_
- Standard     Polished     Powder coat     Bead Blast
- Other \_\_\_\_\_

Project: \_\_\_\_\_

Submitted By: \_\_\_\_\_ Date: \_\_\_\_\_

7974 W. Orchard Dr. \* Michigan City, IN 46360 \* Phone:(219)878-1427\*Fax: (219)874-3626

Email: [steve@ctpanchors.com](mailto:steve@ctpanchors.com) \* [www.ctpanchors.com](http://www.ctpanchors.com)