

CTP GRIP-TIE

CTP 5100 Series Anchor

Veneer ≥ 3"

SUBMITTAL

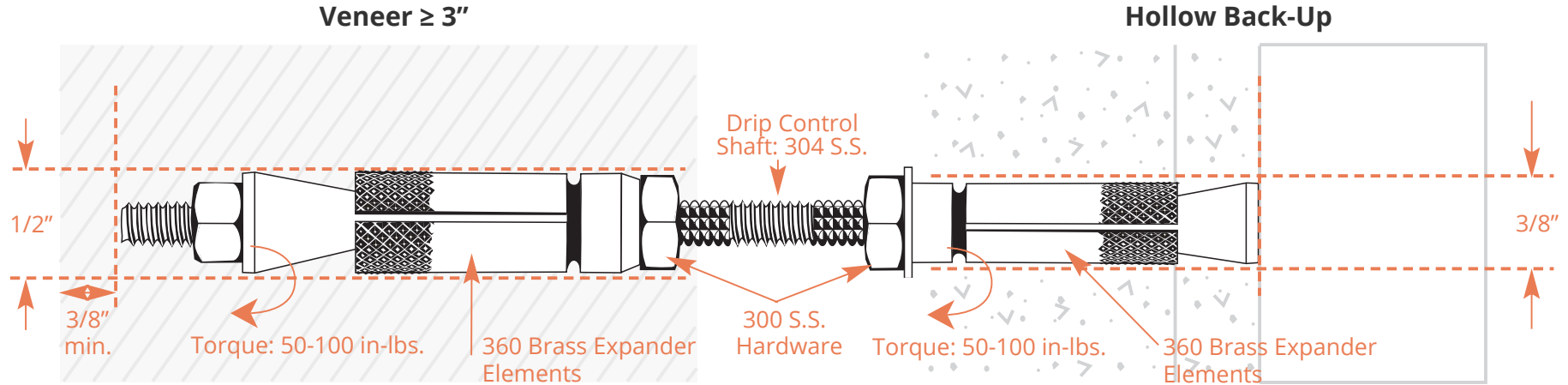

LENGTH			APPROVAL		
<input type="checkbox"/> 5 1/2" (138mm)	<input type="checkbox"/> 7 1/2" (188mm)	<input type="checkbox"/> 9 1/2" (238mm)			
<input type="checkbox"/> 6 1/2" (163mm)	<input type="checkbox"/> 8 1/2" (213mm)	<input type="checkbox"/> Other_____			

• Brass: ASTM B16, Type 360

• S.S : ASTM 580A, Type 304

SPECIFICATIONS

<input type="checkbox"/> 62220-550	Grip-Tie 5100 Series w/ 5-1/2" shaft	CTP-5154
<input type="checkbox"/> 62220-650	Grip-Tie 5100 Series w/ 6-1/2" shaft	CTP-5164
<input type="checkbox"/> 62220-750	Grip-Tie 5100 Series w/ 7-1/2" shaft	CTP-5174
<input type="checkbox"/> 62220-850	Grip-Tie 5100 Series w/ 8-1/2" shaft	CTP-5184

DATE:	APPROVED BY:	DRAWN BY:
SCALE: NTS		REVISED:
PROJECT:		
CUSTOMER:		DRAWING NUMBER: