

SS ThruWall Flashing

Creating an end dam

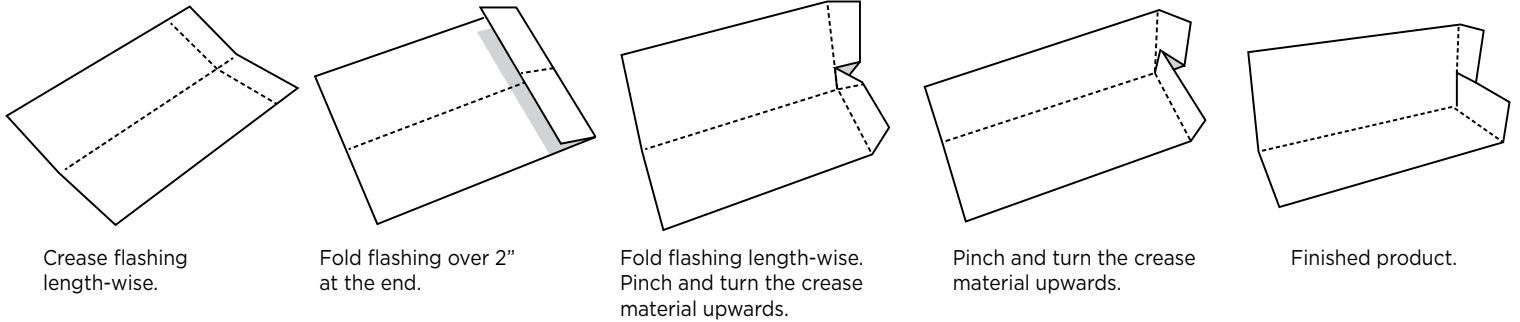

Creating an inside corner

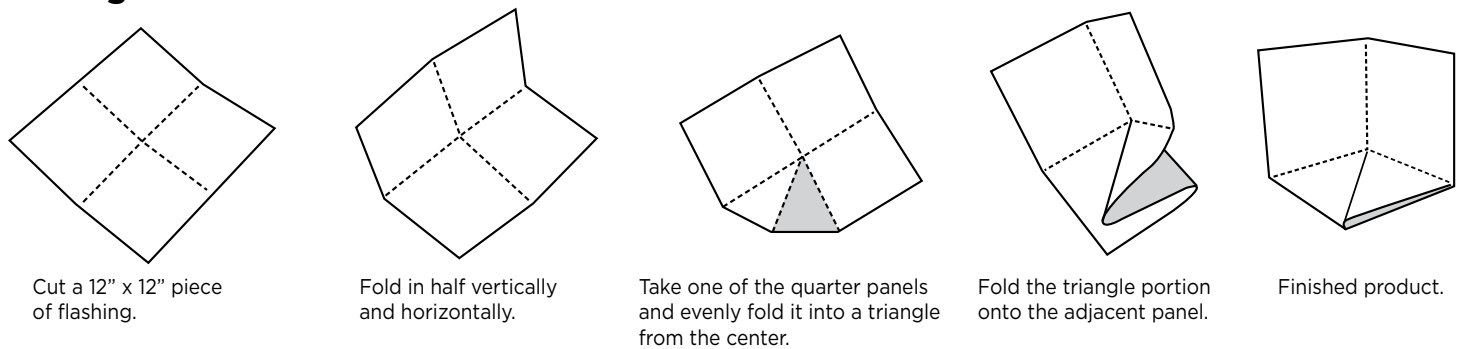

Creating an outside corner

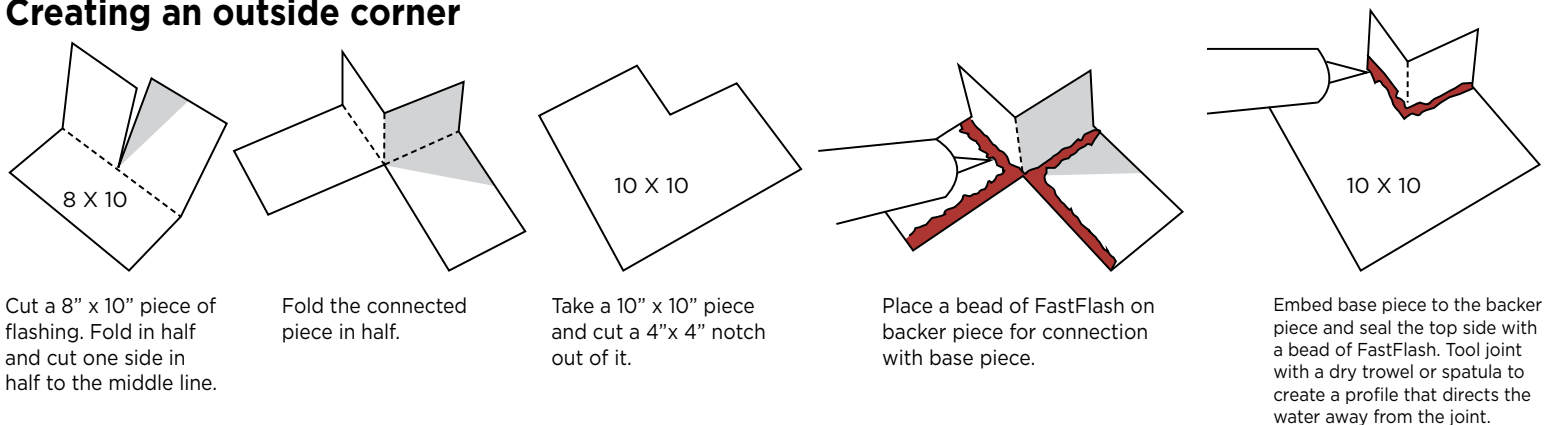

Creating interlocking lap joints

