

FACADE-TIE SYSTEM

Bracket and Anchor system that stabilizes existing veneers to interior wood or metal studs

The Facade-Tie System, formerly called CTP Facade-Tie Bracket, enables exterior masonry facades to be re-attached from the interior of structures. This eliminates any exterior hole drilling, mortar patch matching, or costly scaffolding expenses. This makes the Facade-Tie System ideal for fortifying masonry veneers during remodeling, build-outs or basic building renovations.



EASY TO INSTALL



**NO EXPOSED
HARDWARE**



**CORROSION-
RESISTANT**



NO WEATHER DELAYS



**EASY POST-INSTALL
QUALITY CONTROL**



**SECURES VARIETY OF
WALL MAKEUPS**

There are 2 system options when stabilizing your exterior veneer to the interior studs.

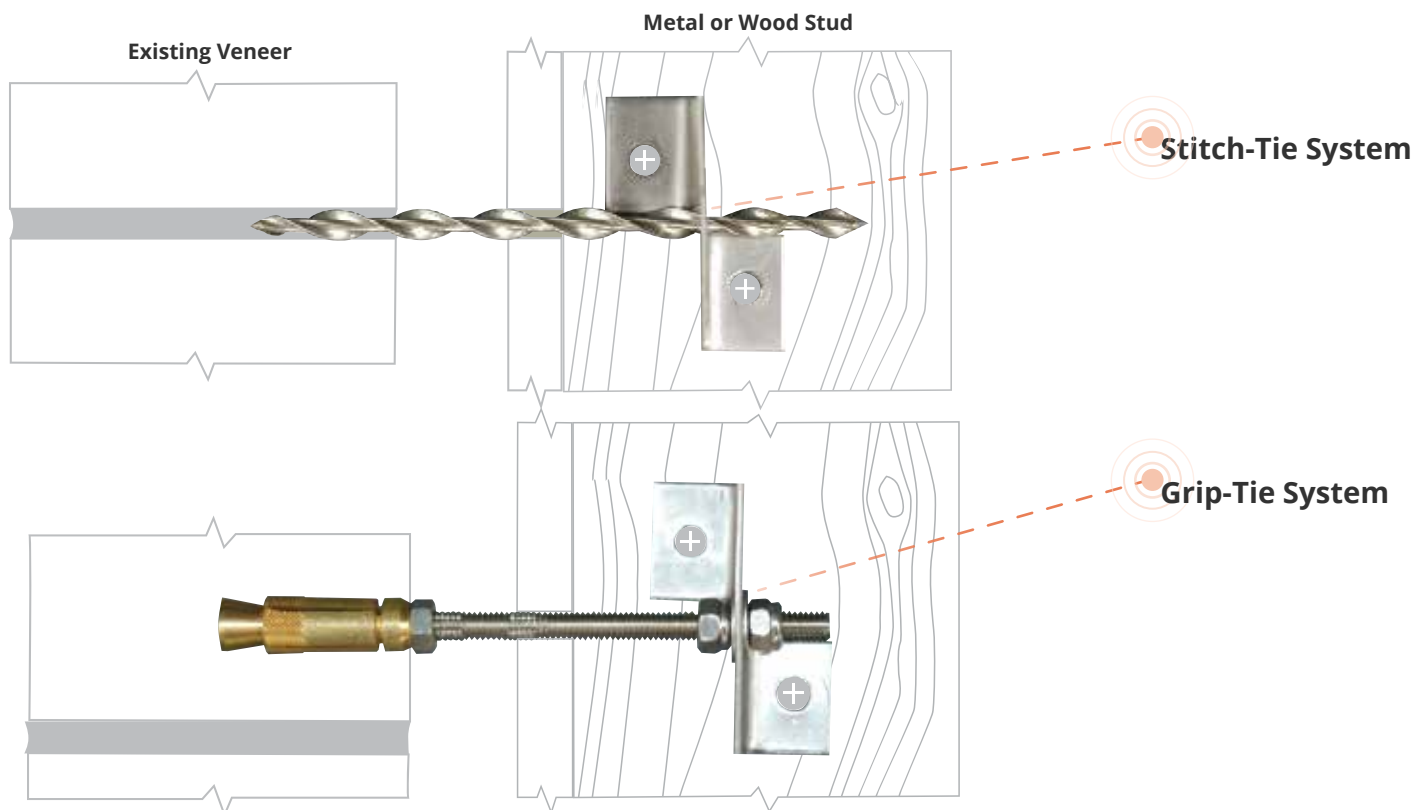



FACADE-TIE SYSTEM

Concealed connections for your facade from your building's structural frame.

Product Line Description

The Facade-Tie System is a facade re-anchoring system and economical solution to fortify and stiffen existing veneers from the parent structure. It is easy to install and operates via mechanical connections. The Facade-Tie System is manufactured of corrosion-resistant materials for long-term durability. It can be attached to the interior structure via dual screw fasteners manufactured of compatible materials that transfer veneer live loading to the building via shear. This reliable load transfer is a result of the brackets' split-plate interface connection.

Facades built of brick, stone, block, precast, etc., can be re-attached from the interior of the structure affordably and without exterior marks. The interior reconnection process eliminates the need for exterior scaffolding. It also keeps the outer surface of the veneer from being compromised by drilled holes and creating aesthetic concerns. The basic intent of the Facade-Tie System assembly is to replicate or supplement the tie integrity of an existing veneer anchoring scenario.

The veneer-to-bracket connection can be accomplished by either the Stitch-Tie® or Grip-Tie anchoring systems. Both are proven masonry anchoring systems that provide installation adjustability, added veneer stiffness, and substantial tension/compression load-resistant qualities. The selection of the anchoring type is a function of performance and installation conditions which may be challenged by the integrity of the free-standing facade or interior space limitations. Note that both anchors are manufactured of stainless steel and/or brass components for long-term performance expectations and a quality installation.

IDEAL FACADE STABILIZATION APPLICATION FOR:

- Hurricane Damage
- Termite Damage
- Flood Damage
- Fire Damage
- Repurposing Buildings
- New Framing



Ultimate Fastener Tension Capacity* Guide (lb)								
* Consult for other conditions not shown	DIAMETER		Facade Material					
	ANCHOR	PILOT HOLE	FACE BRICK	SOLID BRICK	MORTER JOINT (N)	HOLLOW CMU	SOLID CMU	HOLLOW CLAY TILE
Grip-Tie	3/8"	3/8"	1200	800	900	1100	1100	700
	1/2"	1/2"	1500	1300	900	N/R	1200	N/R
Stitch-Tie®	8MM	1/4"	1200	700	700	510	550	460
	10MM	5/16"	1400	700	750	650	550	550

Bracket's Out-of-Plane resistance 600# ultimate



Typical Wood Stud and Facade-Tie System
(Shown with Grip-Tie, SBRA)



Typical Metal Stud and Facade-Tie System
(Shown with Stitch-Tie®)

Whether the Stitch-Tie System or the Grip-Tie System is used, it WILL NOT pull the veneer material to the base structure. The primary goal is to stabilize the veneer from moving any further.



STITCH-TIE SYSTEM

The Stitch-Tie System consists of a Stitch-Tie helical anchor that carves its way through the substrate with the hammer action from a rotary hammer drill.

- Easy and fast to install
- Small pilot hole
- Installed by hammer action
- Threads through sheathing via pilot hole
- Single piece of SS helical anchor
- 8mm or 10mm compatible with same bracket

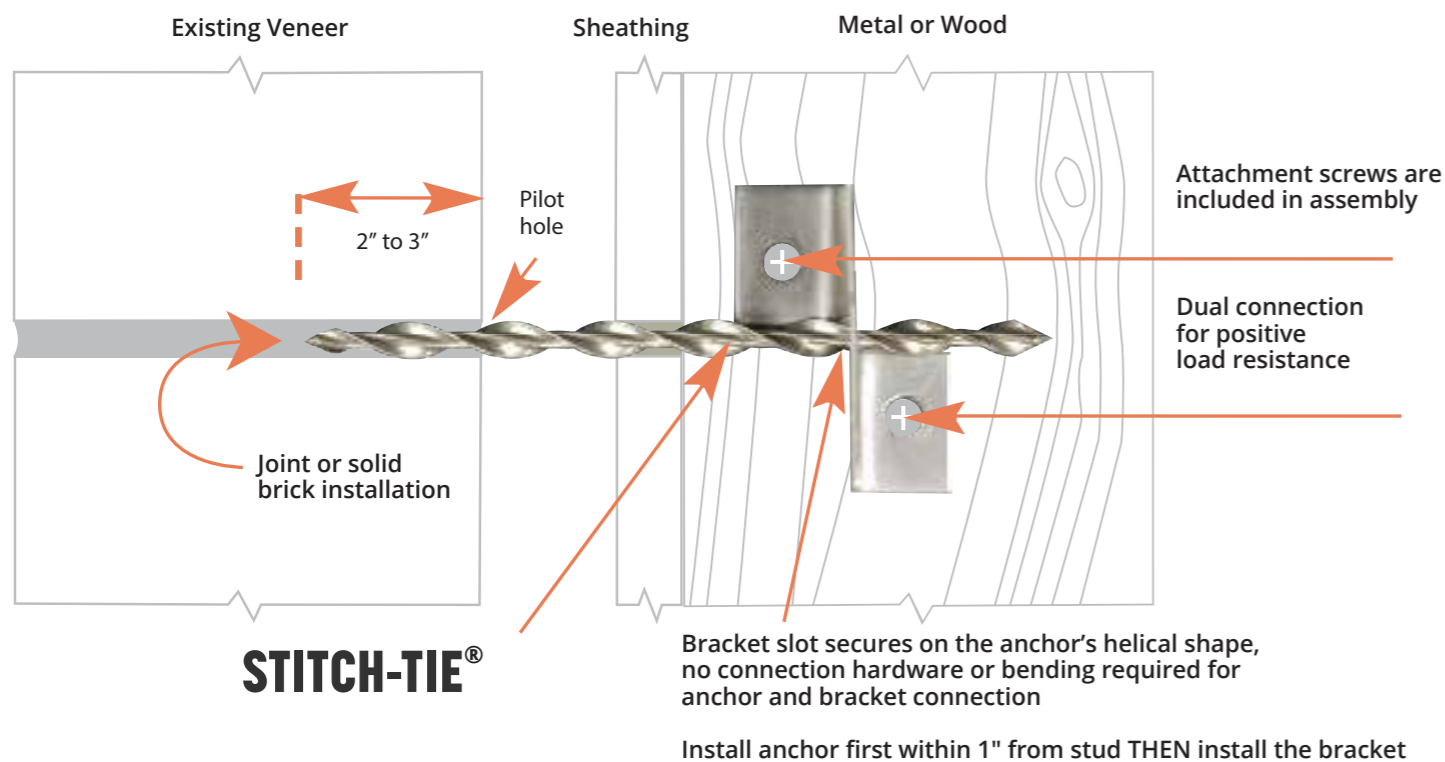

PLANNING GUIDE FOR STITCH-TIE SYSTEM

Measure from interior face of stud to interior face of existing veneer to establish Stitch-Tie Anchor length

Catalog Part #	Face-to-Face Measurement		Stitch-Tie Length
	For 6" Stud Backup	For 4" Stud Backup	
<input type="checkbox"/> 63010-M8N175STS4	6"-8"	4"-6"	7"
<input type="checkbox"/> 63010-M8N200STS4	7"-9"	5"-7"	8"
<input type="checkbox"/> 63010-M8N250STS4	8"-10"	6"-8"	9"
<input type="checkbox"/> 63010-M8N300STS4	9"-11"	7"-9"	10"
<input type="checkbox"/> 63010-M8N350STS4	10"-12"	8"-10"	14"

When Using the Stitch-Tie® (10mm or 8mm Diameter)

Space Facade-Tie Bracket and Stitch-Tie Anchor at:

- 1 tie per - 1.6 sq ft for multiwythe (16"H x 16"V)
- 1 tie per - 2.0 sq ft for seismic or high wind applications (16"H x 18"V)
- 1 tie per - 2.6 sq ft for Residential or Commercial veneer applications. (16"H x 24"V)
- Consult with PROSOCO for other conditions

Remaining items needed to complete the Stitch-Tie System:

- 62135-FTHH: Stitch-Tie Facade Bracket - Mill Galv. with self-tapping screws (Same Bracket is used for 8mm or 10mm Stitch-Tie)
- 63100-ST88T: 8mm Stitch-Tie Economy Setting Tool



GRIP-TIE SYSTEM

The Grip-Tie System consists of a torque-activated Grip-Tie mechanical anchor that expands in the masonry and grips the existing exterior substrate on the interior face of the facade. The torque activation draws the brass cone down the shaft and expands the knurled brass sleeve into the masonry to provide a strong connection. The torque activation provides less impact on the interior face of the facade and is considered a "silent" installation.

- Stiff and strong connection
- "Silent" install
- Installed by torque action
- Less impact on interior face of facade
- Engages directly into interior brick face or mortar joint

PLANNING GUIDE FOR GRIP-TIE SYSTEM

Measure from interior face of stud to interior face of existing veneer to establish Grip-Tie Anchor length

Catalog Part #	Face-to-Face Measurement		Grip-Tie Length
	For 6" Stud Backup	For 4" Stud Backup	
<input type="checkbox"/> 62377-37N550	6"-8"	4"-6"	5.5"
<input type="checkbox"/> 62377-37N650	7"-9"	5"-7"	6.5"
<input type="checkbox"/> 62377-37N750	8"-10"	6"-8"	7.5"
<input type="checkbox"/> 62377-37N850	9"-11"	7"-9"	8.5"

When Using The Grip-Tie (1/2" Diameter Heavy Duty or 3/8" Diameter Standard)

Space Facade-Tie Bracket and Grip-Tie Anchor at:

- 1 tie per - 1.6 sq ft for multiwythe (16"H x 16"V)
- 1 tie per - 2.0 sq ft for seismic or high wind applications (16"H x 18"V)
- 1 tie per - 2.6 sq ft for Residential or Commercial veneer applications. (16"H x 24"V)
- Consult with PROSOCO for other conditions.

Remaining items needed to complete the Grip-Tie Bracket System:

- 62130-FTHH Grip-Tie Facade Bracket - Mill Galv with 2 lock-nuts (SS), washers (SS), and self-tapping screws
- 62900-501 Grip-Tie Hand Setting Tool

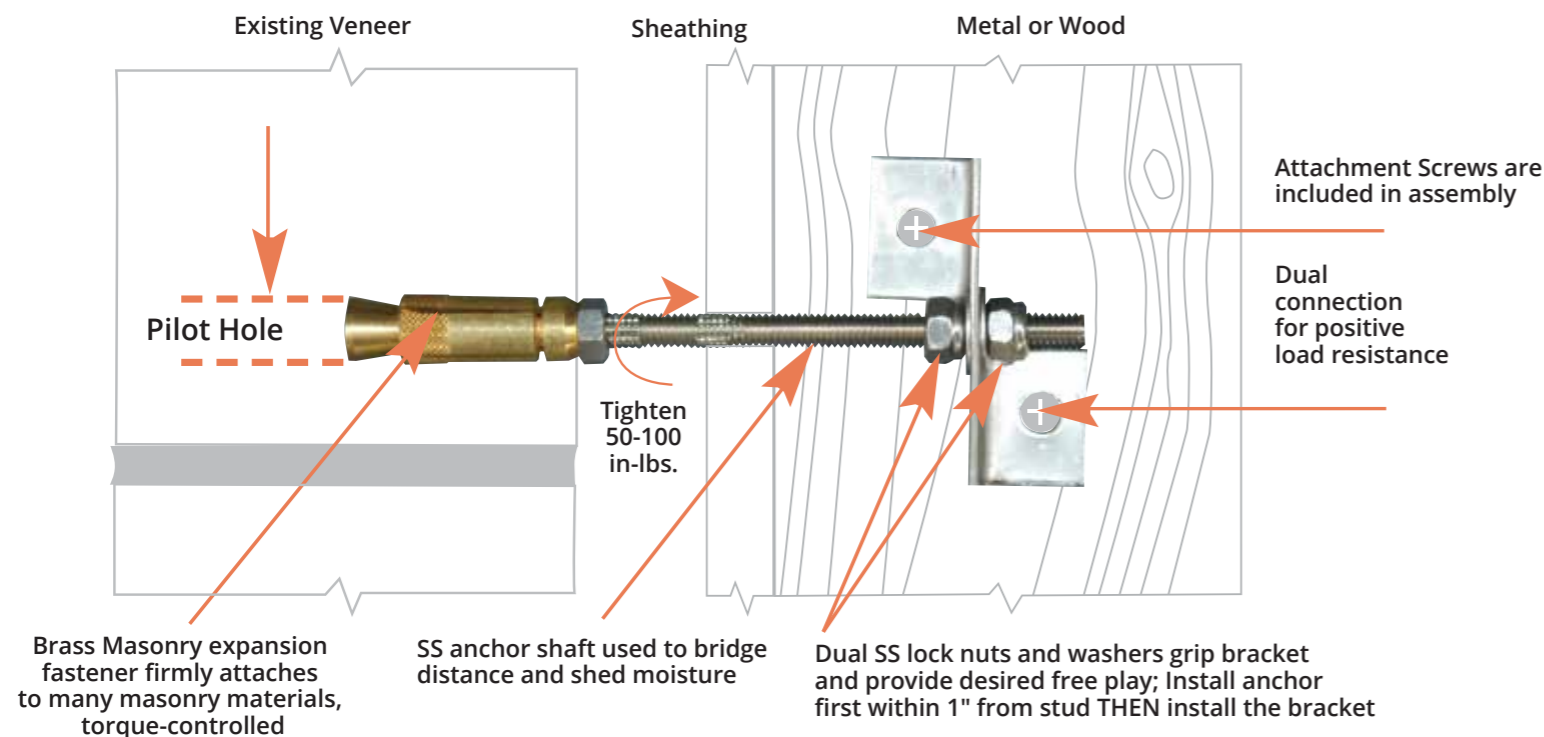

INSTALLATION GUIDE FOR GRIP-TIE SYSTEM



Step 1
Drill 1/2" hole through the sheathing approximately 1/4" - 3/4" from the stud face (parallel with mounting face).

Step 2
On center with 1/2" hole, drill a 3/8" diameter hole in brick veneer 2-1/2" deep blow out drill lines.



Step 3
Thread shaft of SBRA anchor into the Grip-Tie 501 Setting Tool until it bottoms in the tool.



Step 4
Slide tool and anchor assembly through drilled holes until the washer contacts the brick face. Tighten anchor to 40-75 in-lbs torque. Remove tool.



Step 5
Thread (1) SS Lock Nut provided onto anchor shaft and position it about midway of the stud width.



Step 6
Slide on (1) SS washer provided and bracket. Secure the bracket with 2 attachment screws (provided) to the stud.



Step 7
Assemble SS washer and SS lock nut to the exposed shaft and tighten until contact to the bracket is made.

Step 8
Loosen SS lock nut 1 turn of the nut past tight. Installation complete.

INSTALLATION GUIDE FOR STITCH-TIE SYSTEM



Step 1
Drill 1/4" hole through the sheathing approximately 1/4" - 3/4" from the stud face (parallel with mounting face) into brick or joint approximately 2' or greater.



Step 2
Select a Stitch-Tie helical anchor equal to the distance from the stud face to the brick and install per Stitch-Tie installation requirements.



Step 3
Attach Facade-Tie Bracket to the Stitch-Tie anchor.

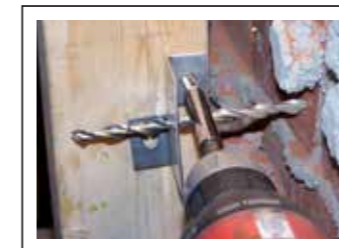

Step 4
Attach the Facade-Tie Bracket to the stud with the supplied hardware.



Step 4
Installation complete.



PROTECTED WITH
BMC II



US Capitol, Washington, D.C.

PROSOCO products cleaned and protected the exterior masonry of what is possibly the most recognizable building in the nation.



R.W. Kern Center, Hampshire College, Amherst, MA

The project team for this pioneering institutional Living Building Challenge-certified building chose PROSOCO for its building envelope air barriers, finished concrete floors and exterior protective treatment.

We've been around awhile.

Since 1939, PROSOCO has been involved some of the world's most recognizable and highest performing buildings.

Grand Central Station, New York, NY

The historic details of New York City's famed Grand Central Station were entrusted to be cleaned by PROSOCO.



Wrigley Building, Chicago, IL

Chicago's iconic skyline wouldn't be the same without the Wrigley Building, whose terra cotta exterior was brightened with PROSOCO cleaners and secured with PROSOCO anchors.

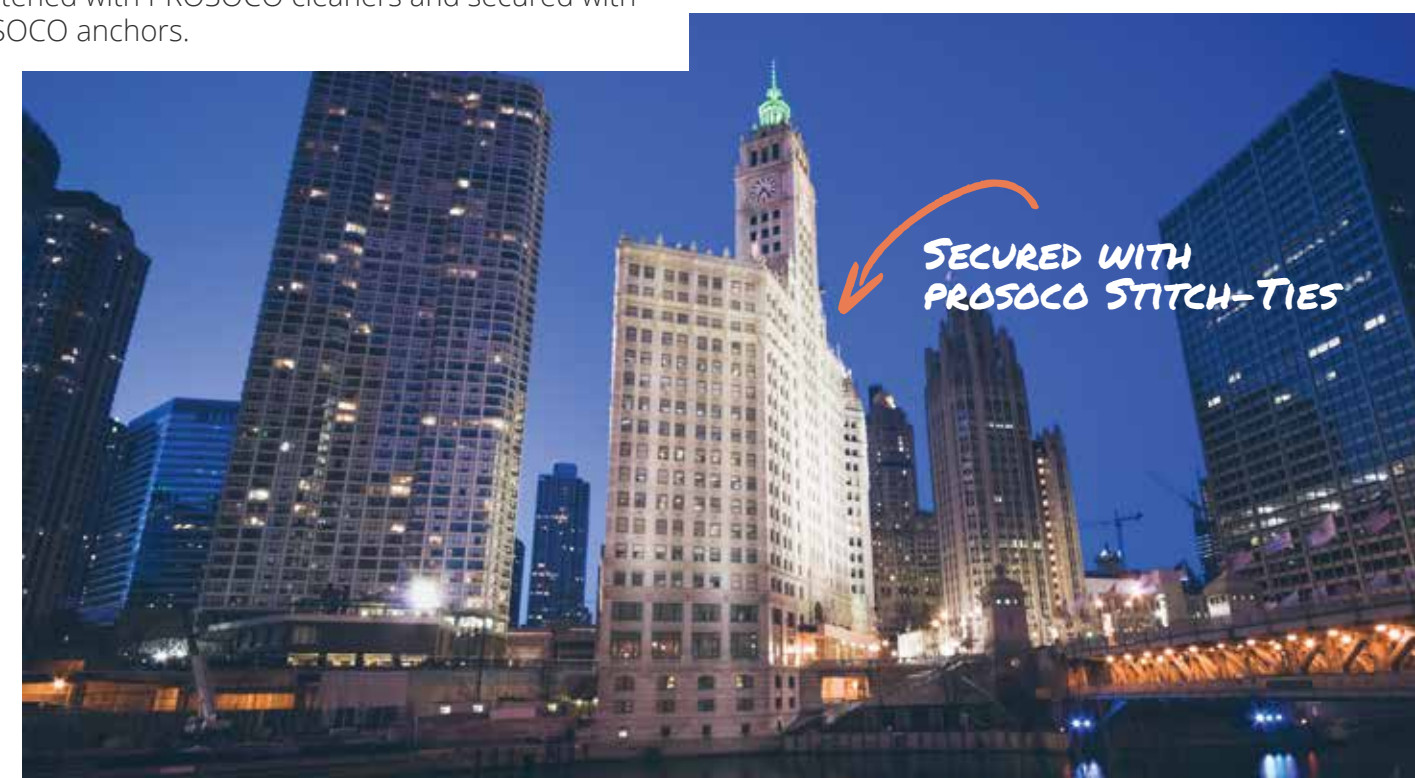

SECURED WITH
PROSOCO STITCH-TIES



Where building meets science

We have invested years and years of resources into testing and developing the best products on the market to improve the performance and durability of our built environment. Here's a look at where we can help you extend the life of your building (it's not just masonry cleaning!).



Anchoring Systems
Secure masonry buildings with restoration anchors and wall ties.

Hard Surface Care
Clean and protect interior and exterior masonry, architectural metal and more.

Air & Water Barriers
Control the leakage of air and water for maximum building envelope performance.

Water Repellents
Protect masonry and increase its service life by locking water out.

Concrete Flooring
Optimize floor performance and aesthetics with hardeners, decorative colors, maintenance cleaners and more.

Hardscapes & Pavers
Enhance the appearance, performance and life of exterior hard surfaces.

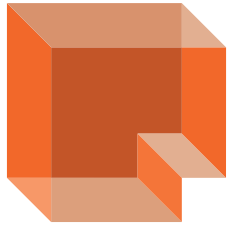

PROSOCO

You. Us. The project.

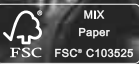

Printed on paper certified by the Forest Stewardship Council. This paper is made of material from well-managed, FSC®-certified forests, and other controlled sources.

© 2020 PROSOCO INC. 10/2020 // CUSTOMER CARE 800-255-4255 // PROSOCO.COM