

MASONRY FASTENER

SUBMITTAL

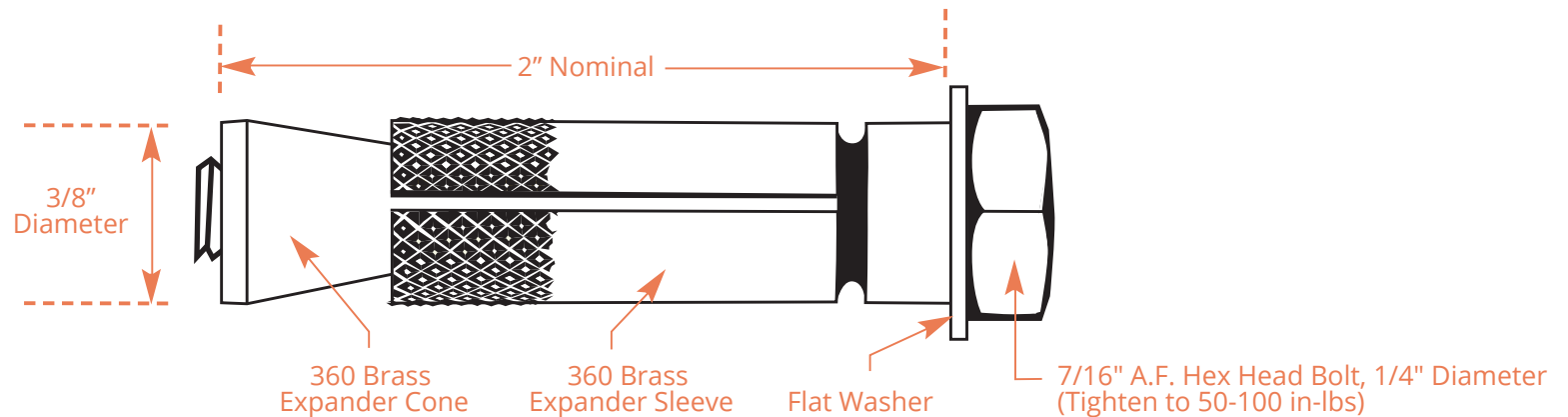

Catalog #	Hardware Material
62376-37N200AWGXZ	Zinc Plated Steel A307 ASME B18.2.1 & ANSI B18.22.1 TYA
62376-37N200AWGS	AISI 304 (18-8) Stainless Steel

Ultimate Pullout Strength (Tension)*

4" Hollow CMU	920 lb
8" Hollow CMU	1,558 lb
8" Grouted CMU	2,538 lb
3,500 psi Concrete	2,013 lb
7,500 psi Concrete	3,377 lb
Solid Brick	1,200 lb
Clay Tile	700 lb
Steel (≥ 5/16" Thick)	2,000 lb

*Each construction site is unique and the appropriate use of this product is the responsibility of the professional of record for the project. This data reflects results of lab, field, and in-house tests and are provided as a guideline for the designer. Site testing is encouraged for the verification of in-situ load capacity. A safety factor of 4 is typically used to determine the allowable working load.