

GRIP-TIE

5300R Series

SUBMITTAL

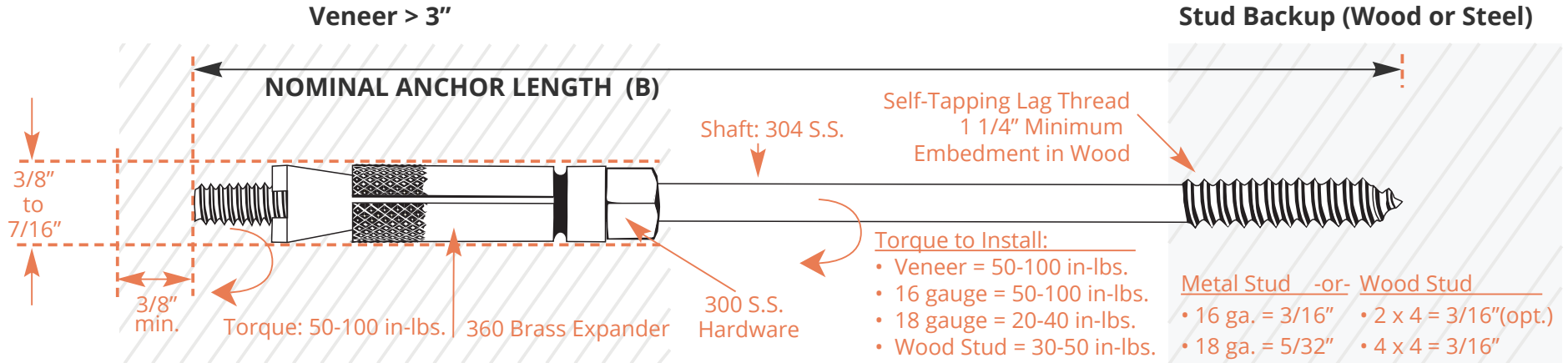

Brass: ASTM B16, Type 360

S.S : ASTM 580A, Type 304

LENGTH		
<input type="checkbox"/> 4 1/2" (113mm)	<input type="checkbox"/> 5 1/2" (138mm)	<input type="checkbox"/> 7 1/2" (188mm)
<input type="checkbox"/> 6 1/2" (163mm)	<input type="checkbox"/> 8 1/2" (213mm)	<input type="checkbox"/> Other _____

SPECIFICATIONS

<input type="checkbox"/> 62250-450	Grip-Tie 5300R Series w/ 4-1/2" lag thread shaft - 3/8" diameter	CTP-5344R
<input type="checkbox"/> 62250-550	Grip-Tie 5300R Series w/ 5-1/2" lag thread shaft - 3/8" diameter	CTP-5354R
<input type="checkbox"/> 62250-650	Grip-Tie 5300R Series w/ 6-1/2" lag thread shaft - 3/8" diameter	CTP-5364R
<input type="checkbox"/> 62250-750	Grip-Tie 5300R Series w/ 7-1/2" lag thread shaft - 3/8" diameter	CTP-5374R
<input type="checkbox"/> 62250-850	Grip-Tie 5300R Series w/ 8-1/2" lag thread shaft - 3/8" diameter	CTP-5384R

DATE:	APPROVED BY:	DRAWN BY: CMS
SCALE: NTS		REVISED:
PROJECT:		
CUSTOMER:		DRAWING NUMBER: