

# FACADE-TIE SYSTEM

# SUBMITTAL

Mill Galvanized Bracket Catalog Part#	
A-Series with GRIP-TIE <input type="checkbox"/> 62130-FTHH	B-Series with STITCH-TIE <input type="checkbox"/> 62135-FTHH
Includes Mounting Hardware	
<input type="checkbox"/> Tek Screw (metal stud)	
<input type="checkbox"/> S.S.Screw (wood stud)	



Galvanized Plate

	Size	Pilot Hole
Grip-Tie	<input type="checkbox"/> 3/8	3/8
	<input type="checkbox"/> 1/2	1/2
Stitch-Tie	<input type="checkbox"/> 8mm	3/16 or 1/4
	<input type="checkbox"/> 10mm	1/4 or 5/16

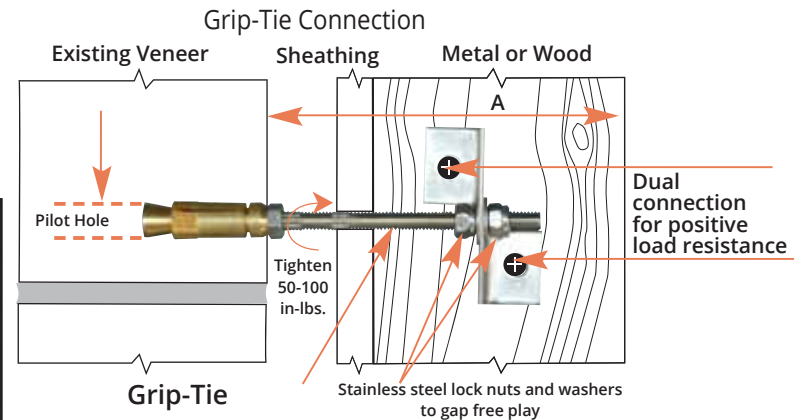

Stitch-Tie Connection

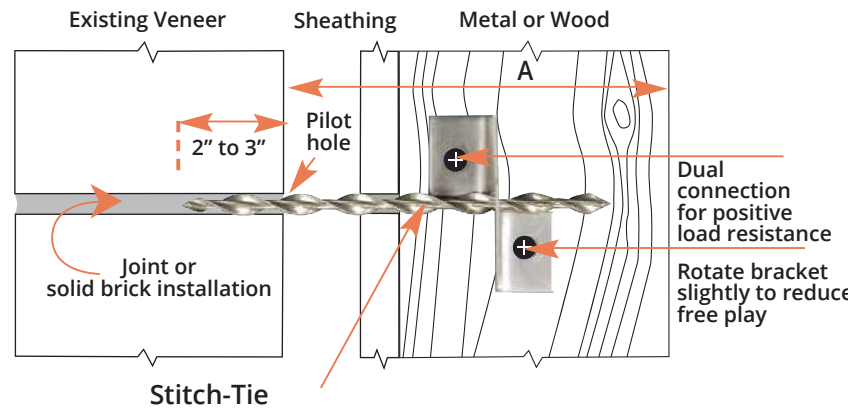

Spacing Per Tie

- 16" H X 16" L
- 16" H X 18" L
- 16" H X 24" L

Stitch-Tie Length	Face-to-face measurement (Dimension "A")	
	For 6" Stud Back up	For 4" Stud Back up
<input type="checkbox"/> 7"	6"-8"	4"-6"
<input type="checkbox"/> 8"	7"-9"	5"-7"
<input type="checkbox"/> 9"	8"-10"	6"-8"
<input type="checkbox"/> 10"	9"-11"	7"-9"
<input type="checkbox"/> Other _____		

Grip-Tie Length	Face-to-face measurement (Dimension "A")	
	For 6" Stud Back up	For 4" Stud Back up
<input type="checkbox"/> 5-1/2"	6"-8"	4"-6"
<input type="checkbox"/> 6-1/2"	7"-9"	5"-7"
<input type="checkbox"/> 7-1/2"	8"-10"	6"-8"
<input type="checkbox"/> 8-1/2"	9"-11"	7"-9"
<input type="checkbox"/> Other _____		
Includes 2 S.S. washers And 2 S.S. lock nuts		